

EN

1920660  
R02

OPERATING MANUAL

# Robot Gun Cleaning Station



## CONTENTS

1.	The Robot Gun Cleaning Station.....	3
2.	Preface .....	3
3.	Identification.....	4
4.	CE marking .....	4
5.	Safety .....	4
5.1	Designated use.....	4
5.2	Responsibilities of the user .....	4
5.3	Personal protective equipment.....	4
5.4	Signs used in the documentation.....	5
5.5	Warning and notice signs .....	5
5.6	Emergency instructions .....	5
5.7	Operation safety.....	5
5.8	Product safety.....	6
6.	Technical data .....	7
6.1	Ambient conditions .....	8
6.2	Weight and dimensions .....	8
6.3	The pneumatic distributor block .....	8
6.4	The electrical clamping block.....	8
6.5	The compressed-air motor.....	9
6.6	The injection unit .....	9
6.7	The wire-cutting device .....	9
6.8	The type plate.....	9
7.	Delivery scope.....	10
7.1	Transport .....	10
8.	Storage.....	10
9.	Functional description.....	11
9.1	The cleaning station sub-assembly .....	11
9.2	The injection unit sub-assembly.....	11
9.3	Wire-cutting device sub-assembly .....	12
9.4	Sub-assembly accessories and options.....	12
10.	Installing the Robot Gun Cleaning Station.....	13
10.1	Connecting to electricity .....	14
10.2	Installing the injection unit.....	15
10.3	Adjusting the anti-spatter fluid .....	16
10.4	Installing the wire-cutting device.....	17
10.5	Attaching the cutting prism.....	18
10.6	Mounting the milling cutter .....	18
10.7	Setting up the clamping position.....	19
10.8	Setting up the compressed-air motor .....	19
10.9	Adjusting the height .....	20
10.10	Establishing the electrical connection .....	21
10.11	Creating the program for cleaning station operation.....	22
10.12	Connecting the pneumatic system .....	23
11.	Using the Robot Gun Cleaning Station .....	24
12.	Withdrawing the Robot Gun Cleaning Station from operation .....	24
13.	Maintenance and cleaning .....	24
13.1	Weekly maintenance.....	24
13.2	Monthly cleaning .....	24
14.	Troubleshooting.....	25
15.	Unmounting.....	26
16.	Disposal .....	26
17.	Materials.....	26

## 1. THE ROBOT GUN CLEANING STATION

This document provides product information for the Kemppi Robot Gun Cleaning Station.

## 2. PREFACE

Congratulations on your purchase of this product. Used correctly, Kemppi products can significantly increase the productivity of your welding and provide many years of economical service.

This operation manual contains important information on the use, maintenance, and safety of your Kemppi product. The technical specifications of the equipment can be found in the chapter "Technical data" and at the end of this manual.

Please read the manual carefully before using the equipment for the first time. For your own safety and that of your work environment, pay particular attention to the safety instructions in the manual.

For more information on Kemppi products, contact Kemppi Oy, consult an authorized Kemppi dealer, or visit the Kemppi Web site: [www.kemppi.com](http://www.kemppi.com).

The specifications presented in this manual are subject to change without prior notice.

### **Disclaimer**

While every effort has been made to ensure that the information contained in this guide is accurate and complete, no liability can be accepted for any errors or omissions. Kemppi reserves the right to change the specification of the product described, at any time, without prior notice. Do not copy, record, reproduce, or transmit the contents of this guide without prior permission from Kemppi.

### 3. IDENTIFICATION

The Robot Gun Cleaning Station is used in industry and in the trade for automatic cleaning of the gas nozzle interior of MIG/MAG welding guns. The cleaning station helps to extend the service life of the welding gun and the maintenance intervals. These instructions describe the Robot Gun Cleaning Station product only. The Robot Gun Cleaning Station must be operated only as supplied or equipped with authentic Kemppi spare parts.

### 4. CE MARKING

This device fulfils the requirements of the following EU directives:

- The Machinery Directive, 2006/42/EC
- The EMC Directive, 2004/108/EC
- The RoHS Directive, 2011/65/EU

### 5. SAFETY

Read and follow the additional safety instructions enclosed.

#### 5.1 Designated use

The Robot Gun Cleaning Station forms a part of the robot welding system. It may be used only for the purpose described in these instructions, in the manner described. Follow the operation, maintenance, and servicing conditions whenever using the device.

Any other use is considered contrary to the intended use.

Unauthorized conversions or power-increasing modifications are not allowed.

The warranty does not cover wear parts and damage due to overloading or improper use.

#### 5.2 Responsibilities of the user

- Keep the operating instructions within easy reach in the location of the device for reference, and include the operating instructions when handing over the product.
- Installation, operation, and maintenance work may only be carried out by qualified personnel. Qualified personnel are persons who, on account of their special training, knowledge, experience, and familiarity with the relevant standards, are able to assess the tasks assigned to them and identify possible dangers.
- Keep all other people out of the work area.
- Follow the accident prevention regulations of the relevant country.
- Ensure good lighting of the work area, and keep it clean.

- Observe the following standards and guidelines in particular:
  - 89/391/EEC: Directive on the introduction of measures to encourage improvements in the safety and health of workers at work
  - 2009/104/EC: Directive concerning the minimum safety and health requirements for the use of work equipment by workers at work
  - 2004/108/EC: Directive on the harmonization of the laws of the Member States relating to electromagnetic compatibility The occupational health and safety regulations of the country in question
  - Regulations on occupational safety and accident prevention

#### 5.3 Personal protective equipment

To avoid danger to the user, using personal protective equipment (PPE) is recommended in these instructions.

PPE consists of the following

- Protective clothing
- Safety goggles
- A class-P3 respiratory mask
- Gloves
- Safety shoes

## 5.4 Signs used in the documentation

Items in the manual that require particular attention, to minimize damage and personal injury, are indicated with a three-level notification and warning system. Read these sections carefully, and follow the instructions.

 *Note: Note items give the user a useful piece of information.*

 *Caution: A caution item describes a situation that may result in damage to the equipment or system.*

 *Warning: Warnings describe a potentially dangerous situation. If not avoided, it will result in personal harm or fatal injury.*

## 5.5 Warning and notice signs

The following warning and notice signs can be found on the product:

 *Read and observe the operating instructions!*

 CAUTION



 *Wear ear and eye protection!*



*Warning against automatic start-up!*

*Warning against hand injury!*

These markings must always be legible. They must not be covered, obscured, painted over, or removed.

## 5.6 Emergency instructions

In the event of an emergency, immediately interrupt the following:

- The power supply
- The flow of compressed air

Further measures are described in the operating instructions or in the documentation of other peripheral devices.

## 5.7 Operation safety

Please study these operation safety instructions and respect them when installing, operating, and servicing the machine.

### The welding arc and spatter

The welding arc harms unprotected eyes. Also be careful with reflected flashes from the arc. The welding arc and spatter burn unprotected skin. Use safety gloves and protective clothing.

### Danger of fire or explosion

Pay attention to fire safety regulations. Remove flammable or explosive materials from the welding location. Always reserve sufficient fire-fighting equipment at the welding location. Be prepared for hazards in special welding jobs – for example, the danger of fire or explosion in welding of container-type work pieces.

 *Fire can break out from sparks even several hours after the welding is done!*

### Cables

Always check the cables before operating the equipment. Replace damaged cables without delay.

Damaged cables may cause injury or start a fire. Connection cables must not be compressed or come in contact with sharp edges or hot work pieces.

### The welding power circuit

Isolate yourself by using proper protective clothing, and do not wear wet clothing. Never work on a wet surface or use damaged cables. Do not place the MIG gun or welding cables on the welding machine or on other electric equipment. Do not press the MIG gun's switch if the gun is not directed towards a work piece.

### Welding fumes

Make sure that there is sufficient ventilation during welding. Take special safety precautions when welding metals that contain lead, cadmium, zinc, mercury, or beryllium.

## 5.8 Product safety

### Hazards caused by improper use

If improperly used, the device can present risks to people and physical property.

- Use the device in line with its designated use only.
- Do not convert or modify the device to enhance its performance without appropriate authorization.

The device may only be used by qualified personnel.

- The product has been developed and manufactured in accordance with state-of-the-art technology and the recognized safety standards and regulations. These operating instructions warn you against unavoidable residual risks to users, third parties, devices, and other physical property. Disregarding these warnings may result in risks to human life and health, harm to the environment, or other physical damage.
- The product may only be operated in unmodified, technically perfect condition, within the limits described in these instructions.
- Always observe the limit values specified in the technical data. Overloads lead to destruction.
- Safety features of the device must never be disassembled, bridged, or otherwise bypassed.
- During welding work outdoors, use suitable protection against the weather conditions.
- Check the electrical device for any damage and for proper functioning in accordance with its designated use.
- Never expose the electrical device to rain, and avoid damp or wet environments.
- Protect yourself from electrical accidents by using insulating mats and wearing dry clothing.
- Never use the electrical device in areas subject to a risk of fire or explosion.
- Arc welding may cause damage to the eyes, skin, and hearing. When working with the device, always use the prescribed protective equipment.
- Metal vapors, especially from lead, cadmium, copper, and beryllium, are all hazardous to the health! Ensure the use of sufficient ventilation or extraction systems. Always ensure compliance with the legal limit values.

- Using clean water, rinse work pieces that have been degreased with chlorinated solvents, to prevent the risk of phosgene gas forming. Do not place degreasing baths containing chlorine in the vicinity of the welding area.
- Adhere to the general fire protection regulations, and remove flammable materials from the vicinity of the welding area before starting work.
- Keep suitable fire-extinguishing equipment at the work location, ready for use.

## 6. TECHNICAL DATA

Figure 1: Version with a long support

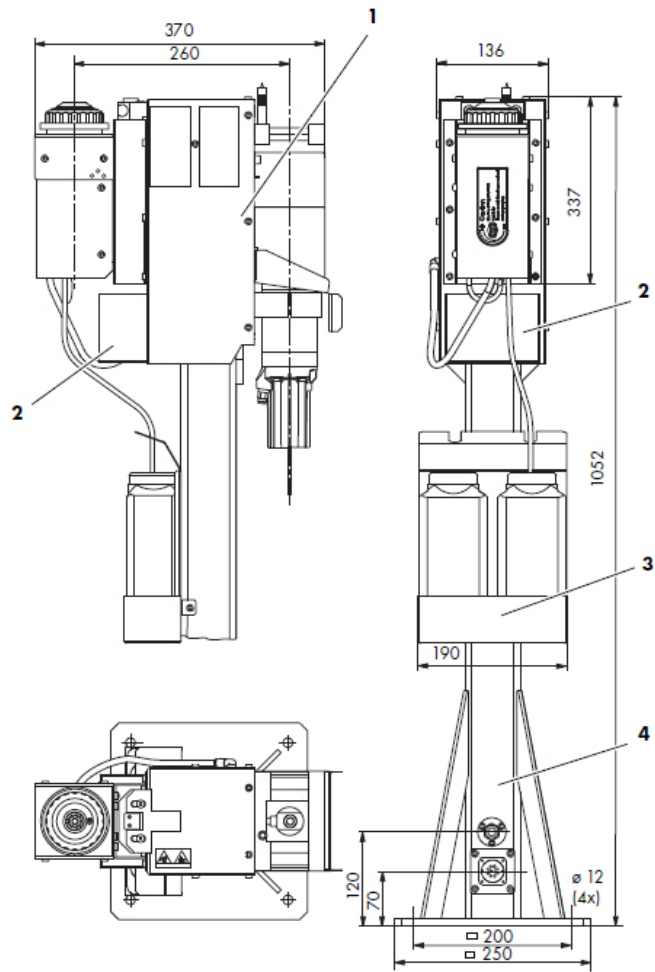

1. Cleaning unit
2. Collecting tray
3. Bottle-holder for anti-spatter bottle
4. Support stand with base plate

Figure 2: Version with a short support

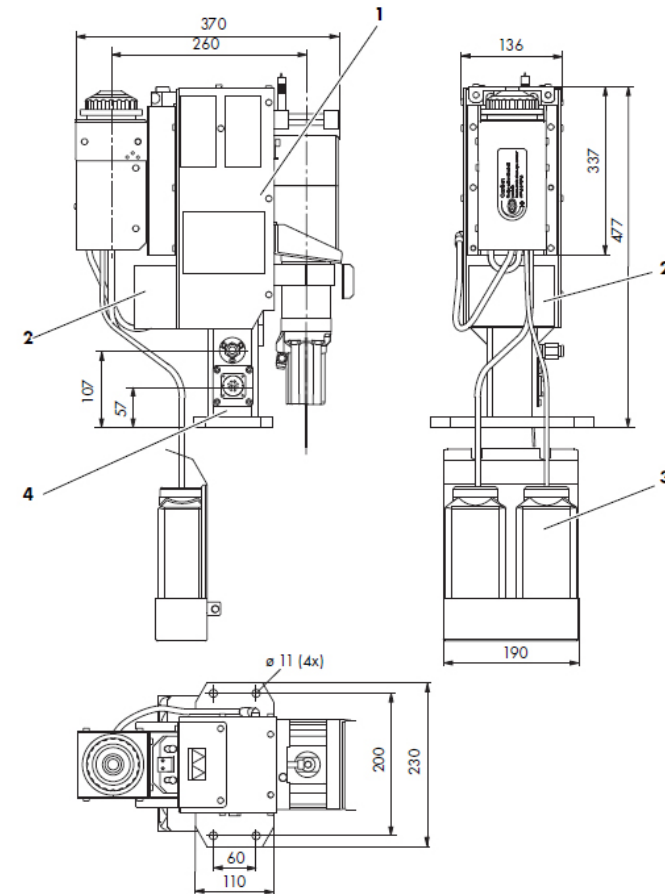

1. Cleaning unit
2. Collecting tray
3. Bottle-holder for anti-spatter bottle
4. Support stand with flange plate

## 6.1 Ambient conditions

This section describes suitable ambient conditions for the Robot Gun Cleaning Station.

Table 1: Ambient conditions

<i>Ambient temperature</i>	5 °C to 50 °C
<i>Transport and storage</i>	-10 °C to 55 °C
<i>Relative humidity</i>	up to 90% at 20 °C

## 6.2 Weight and dimensions

This section describes the Robot Gun Cleaning Station unit's weight and dimensions.

Table 2: Weight and dimensions

<i>Weight</i>	approx. 30 kg	approx. 22.3 kg
<i>Dimensions</i>	approx. 255 mm × 337 mm × 1052 mm	Approx. 255 mm × 337 mm × 477 mm

## 6.3 The pneumatic distributor block

This section describes the Robot Gun Cleaning Station's pneumatic distributor block.

Table 3: Pneumatic distributor block

<i>Compressed air connection</i>	G1/4"
<i>Internal width</i>	min. Ø 6 mm
<i>Nominal pressure</i>	6 bar
<i>Working pressure</i>	6–8 bar
<i>Quality of compressed air (ISO 8573-1:2010)</i>	min. class 4

## 6.4 The electrical clamping block

This section describes the Robot Gun Cleaning Station's electrical clamping block.

Table 4: Electrical clamping block

<i>Operating voltage / internal operating voltage</i>	24 V DC / 200 mA
<i>Protection class</i>	IP21
<i>3 inputs of the 5/2 directional valves</i>	
<i>Activation</i>	24 V DC
<i>Power consumption per valve 2 outputs of the inductive proximity switch (normally open switch) (PNP ≠ positive switching / NPN ≠ negative switching)*</i>	10–30 V DC
<i>Operating voltage</i>	10–30 V DC
<i>Current consumption</i>	approx. 4 mA (24 V)
<i>Allowed residual ripple</i>	V <sub>ss</sub> < 10%
<i>Permanent current per proximity switch</i>	max. 100 mA
<i>Voltage drop</i>	approx. 1.5 V (200 mA)

\* See the nameplate.



## 6.5 The compressed-air motor

This section describes the Robot Gun Cleaning Station's compressed-air motor.

Table 5: Compressed-air motor

<i>Pneumatic motor's nominal speed with oiled air</i>	approx. 650 rpm at 6 bar
<i>Air consumption</i>	approx. 400 l/min
<i>Repository volume (anti-spatter fluid)</i>	1 l
<i>Air supply connection</i>	internal width 6 mm
<i>Max. torque</i>	8 Nm

## 6.6 The injection unit

This section describes the Robot Gun Cleaning Station's injection unit.

Table 6: Injection unit

<i>Injection unit</i>	1-liter bottle capacity
<i>Operating pressure</i>	max. 6 bar
<i>Max. actuation time</i>	4 s

Consumption of anti-spatter fluid depends on the dosage setting.

## 6.7 The wire-cutting device

This section describes the Robot Gun Cleaning Station's wire-cutting device.

Table 7: Wire-cutting device

<i>Cutting capacity at 6 bar</i>	
Solid wire	up to 1.6 mm
Cutting time	1.0 seconds

## 6.8 The type plate

The Robot Gun Cleaning Station unit is labeled with a nameplate on the back as shown in the figure.

Figure 3: The type plate

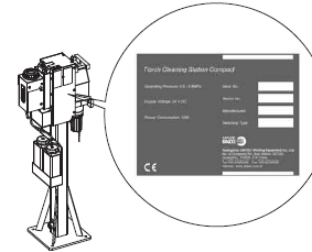

Before contacting the service staff, please remember to check the device type, device number, ID number, year of construction, and switching type.

## 7. DELIVERY SCOPE

The standard delivery includes the following components:

- The Robot Gun Cleaning Station components described in this manual
- A connection set with non-return valve (may be pre-assembled)
- Anti-spatter fluid (1-liter bottle)
- Operating instructions
- Support stand with base plate

The equipment parts and wear parts are ordered separately. Order data and part codes for the equipment parts and wear parts can be found in the current Kemppe spare-parts and wear-parts lists. The contact information for consulting and for placing orders can be found on the Internet, via [www.kemppi.com](http://www.kemppi.com).

### 7.1 Transport

The components are carefully checked and packed; however, damage may still occur during shipping.

<i>Checking procedure on receipt of goods</i>	Check that the shipment is correct by referring to the shipping note.
<i>In case of damage</i>	Check the package and components for damage (perform a visual inspection).
<i>In the event of problems</i>	If the goods have been damaged during transport, contact the last carrier immediately. Keep the packaging (for possible checks by the carrier).
<i>Packaging for return of the goods</i>	Use the original packaging and the original packaging materials. If you have questions about the packaging and safety during shipment, please consult your supplier.

## 8. STORAGE

The physical conditions for storage in a closed room are -10 °C to 55 °C.

## 9. FUNCTIONAL DESCRIPTION

For cleaning, the torch is clamped with the cylindrical part of the gas nozzle in the clamping device. The milling cutter, which is configured to match the gas nozzle and torch geometry, moves into the gas nozzle's interior by means of a stroke movement and removes adhered welding spatter. At the same time, the gas nozzle interior may be blasted with compressed air through the cable assembly (optional). Hereby, the cleaning process is optimized in connection with an optional anti-spatter application.

### 9.1 The cleaning station sub-assembly

The cleaning station sub-assembly is depicted in the figure below.

1. Motor cover
2. Compressed-air motor with integrated stroke
3. Device cover
4. Injection unit
5. Collecting device
6. Anti-spatter bottles with mounted bottle-holder
7. Compressed air connection, DN10
8. Electrical device connection
9. Wire-cutting device
10. Clamping device for the welding torch with clamping prism

Figure 4: Cleaning station sub-assembly

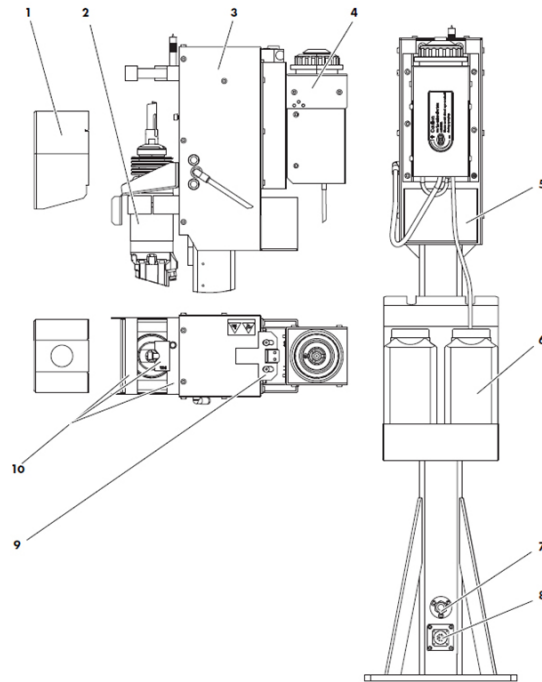

### 9.2 The injection unit sub-assembly

The injection unit sub-assembly is depicted in the figure below.

Figure 5: Injection unit sub-assembly

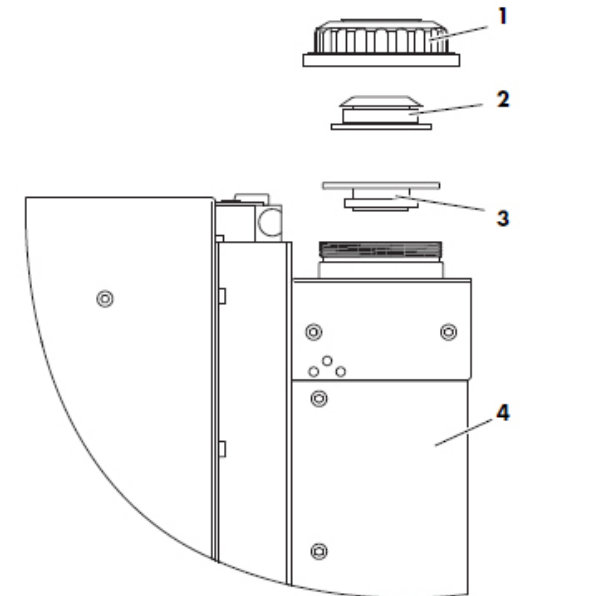

1. Cover for injection unit
2. Rubber gasket for gas nozzle of the welding torch
3. Thrust ring
4. Injection unit, complete

### 9.3 Wire-cutting device sub-assembly

The wire-cutting device sub-assembly is depicted in the figure below.

Figure 6: Wire-cutting device sub-assembly

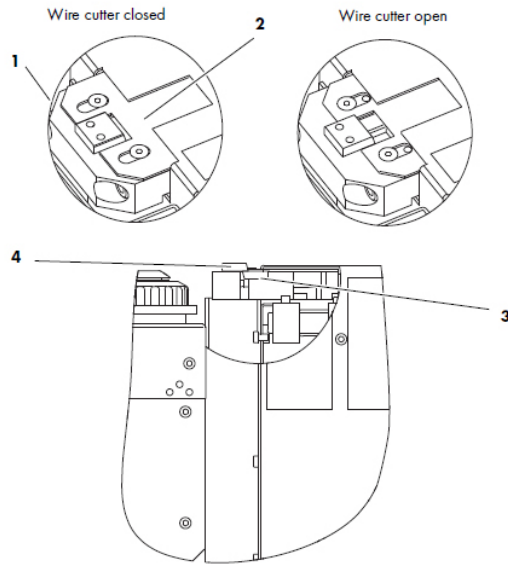

1. Wire-cutting device
2. Protection plate
3. Movable cutting plate
4. Fixed cutting plate

### 9.4 Sub-assembly accessories and options

This section describes the sub-assembly accessories and options.

Table 8: Sub-assembly accessories

<i>Prism</i>	Anti-twist fastening with a cylinder-head screw (M8×20) in the clamping device (depending on the diameter of the gas nozzle)
<i>Milling cutter</i>	Milling cutter dimensions determined on the basis of the gas nozzle and torch geometry for an immersion depth of up to 50 mm (the cutter is available for all standard WH and robot torch versions)

Table 9: Sub-assembly options

<i>Maintenance unit</i>	ID 830.0075
	Unit consisting of a filter regulator and oiler
	The function of separating solid particles from the compressed air and adding atomized oil to lubricate the pneumatically driven components

## 10. INSTALLING THE ROBOT GUN CLEANING STATION

This section describes how to install the Robot Gun Cleaning Station unit.

**!** *Risk of injury due to unexpected start-up*

For the entire duration of maintenance, servicing, unmounting, and repair work, the following instructions must be adhered to:

- Switch off the power supply.
- Cut off the compressed air supply.
- Pull the power plug.

The parts of the system are depicted in the figure below.

Figure 7: Installing the Robot Gun Cleaning Station

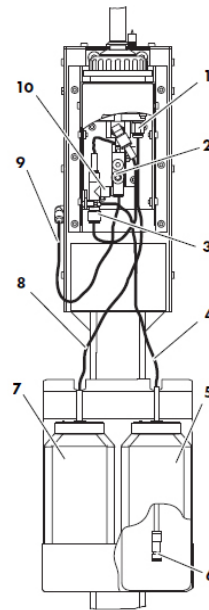

1. Return connection (pre-mounted)
2. Setting for the amount of suction air
3. Connection of anti-spatter system to injection unit
4. Suction hose
5. Anti-spatter bottle (full)
6. Non-return valve
7. Anti-spatter drain bottle
8. Hose
9. Compressed-air connection (pre-mounted)
10. Suction connection (pre-mounted)

### Proceed as follows:

1. Connect the two hoses (4 and 8) to the applicable bottles to put the injection unit of the welding torch into operation.

All other connections for compressed air are pre-mounted at the factory.

**i** *Ensure that the non-return valve (6) is attached to the suction hose (4).*

2. Connect the device through the compressed-air hose.

Figure 8: Connection for compressed air, DN10

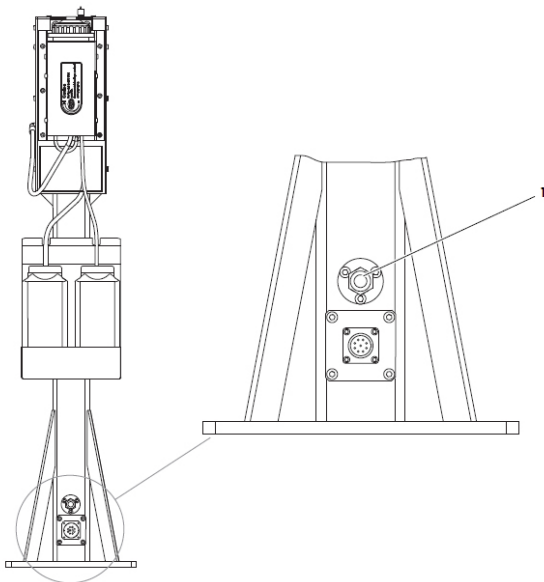

The operating pressure should be 6 bar. If the supply pressure for compressed air is under 6 bar, the cutting capacity of the wire cutter and the speed of the compressed-air motor will be lower. This will reduce the performance of the torch-cleaning station.



We recommend to operate the device with cleaned and oiled compressed air.

An applicable maintenance unit is available as an accessory.

## 10.1 Connecting to electricity

This section describes how to connect the Robot Gun Cleaning Station to electricity.

### Proceed as follows:

1. Connect the cleaning station of the welding torch to the power supply through an integrated plug connection.

The necessary control signals too are transmitted through this plug.

Figure 9: Electrical connection

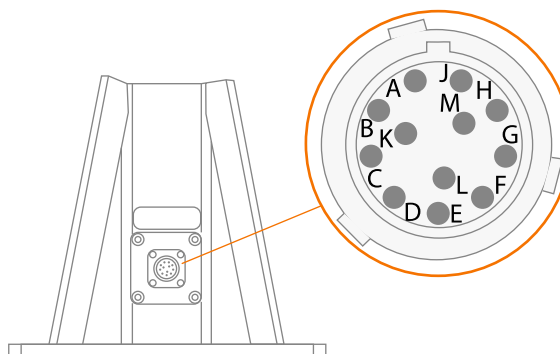

Operating voltage	1/A	PE
	2/B	0V
	3/C	24V DC / 200 mA (com)
Input	4/D	Clamp closed / wire cutter on (Y3), 24 V DC / 2.8 W
	5/E	Lift up (Y1), 24 V DC / 2.8 W
	6/F	Motor rotation (Y2), 24 V DC / 2.8 W
Output	7/G	Lift down, 24 V DC / max. 100 mA
	8/H	Clamp open, 24 V DC / max. 100 mA
	9/I	n.c



Ready-to-use control leads are available in lengths of 5 and 10 m (optional).

For electrical connection, check device type NPN resp. PNP.

## 10.2 Installing the injection unit

This section describes how to install the Robot Gun Cleaning Station's injection unit.

The injection unit's parts are depicted in the figure below. The numbering in the steps of the procedure refers to this figure.

Figure 10: Injection unit

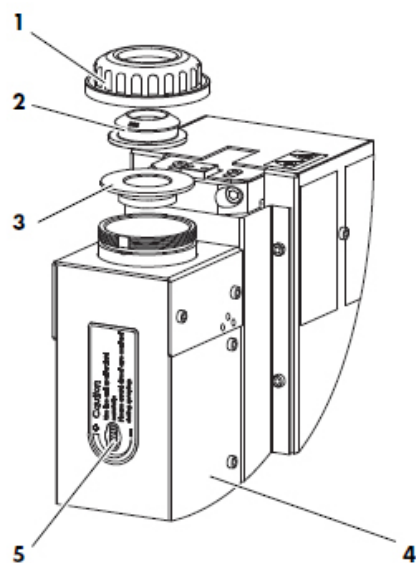

1. Cover for injection unit
2. Rubber gasket for welding torch's gas nozzle
3. Thrust ring
4. Injection unit, complete
5. Adjusting screw for the dosing of anti-spatter fluid

### Proceed as follows:

1. Before you operate the device, mount the rubber gasket, fitting the gas nozzle of the welding torch.

Figure 11: Rubber gasket

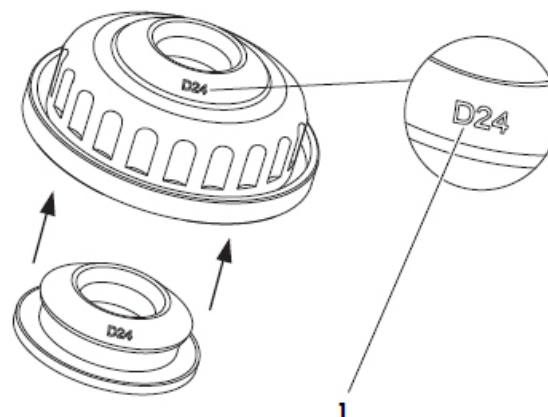

1. Mark the gas nozzle diameter of the welding torch.
2. Loosen the cover (1).
3. Attach the rubber gasket (2) to the cover (1).

Insert the rubber gasket (2) into the cover (1) with light pressure. The special design of these two components prevents unintentional dropping of the rubber gasket.

### 10.3 Adjusting the anti-spatter fluid

This section describes how to adjust the anti-spatter fluid.

The parts of the system are depicted in the figure below.

Figure 12: Adjusting the anti-spatter fluid

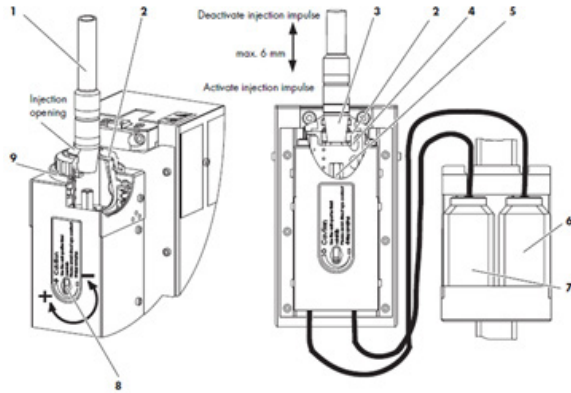

1. Welding torch
2. Rubber gasket for gas nozzle
3. Gas nozzle
4. Thrust ring
5. Injection nozzle
6. Anti-spatter bottle (full)
7. Drain bottle
8. Adjusting screw (anti-spatter volume control)
9. Cover

**i** Make sure that the welding torch / gas nozzle is placed concentrically over the injection unit.

#### Proceed as follows:

1. Place the welding torch (1) over the injection opening.
2. Move the welding torch (1) slowly downwards (in the direction of the arrow).

Hereby, the rubber gasket is "opened." The immersion depth of the welding torch is limited by the stroke of the injection unit.

3. Move the gas nozzle, with the front side toward the thrust ring.

Move the welding torch further down to activate the injector function.

**i** Pay attention to the max. stroke of the injection unit.

Figure 13: Stroke movement of the injection unit

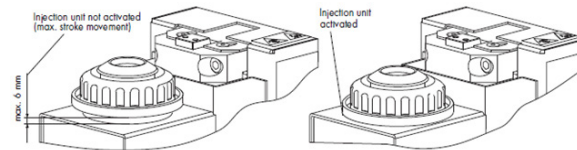

**i** Pay attention to the max. stroke movement for injection.

- The max. stroke travel (traversing movement of the welding torch) should not exceed 6 mm. We recommend a maximum injection impulse of 3 s. The injection pulse is reset upon moving out of the injection unit.
- Use the adjusting screw (8) to adjust the amount of anti-adhesives per injection impulse.

- The residual oil of the anti-spatter application from the injection unit is collected in the drain bottle (7) and can be reused after it is purified of particulate matter.
- Pay attention to the max. stroke movement for injection.
- 4. Manually activate the device via the cover, to set the dosing of the anti-adhesives.

**i** When setting the anti-spatter adjustment manually, wear safety goggles.

You can activate the injection pulse by pressing down lightly on the cover. The injection pulse should be activated for a maximum duration of two seconds.

You can assess the amount of atomized anti-spatter substance by the spray mist produced.

You can increase or reduce the amount of anti-spatter substance by using the adjusting screw (8).

**i** A small amount of anti-spatter substance is sufficient to achieve the desired effect.



## 10.4 Installing the wire-cutting device

This section describes how to install the wire-cutting device.

The parts of the system are depicted in the figure below.

Figure 14: Installing the wire-cutting device

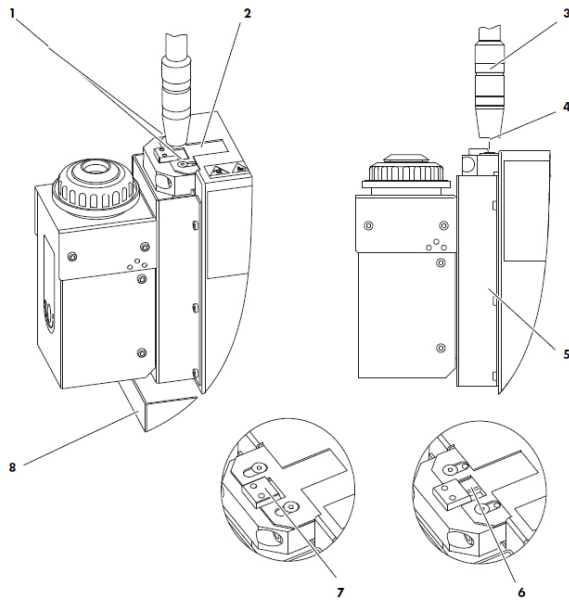

1. Countersunk screw, M5x20
2. Protection plate
3. Welding torch
4. Stick-out (SO) – free wire end
5. Guiding plate for wire clippings
6. Movable cutting plate
7. Fixed cutting plate
8. Container for wire clippings

### Proceed as follows:

1. For better access, loosen the protection plate and move it backwards.
2. Move the welding torch to the cutting position.

**i** Pay attention to the desired stick-out length.

3. Move the free wire end to the fixed cutter (at the lower cutting edge).
4. As soon as you have programmed the desired cutting length, the protection plate must be moved forward again. The gap between the fixed cutter and the protection plate should be  $< 4$  mm.

**i**

*If the cutting plates reach their wear limit (possible results include poor cutting quality, jamming of the device, and incomplete cutting), the cutting plates do not need to be replaced at once.*

*Program a new cutting position in a new place in the area of the cutting plates.*

## 10.5 Attaching the cutting prism

This section describes how to fasten the cutting prism in place.

The parts of the system are depicted in the figure below.

Figure 15: Installing the wire-cutting device

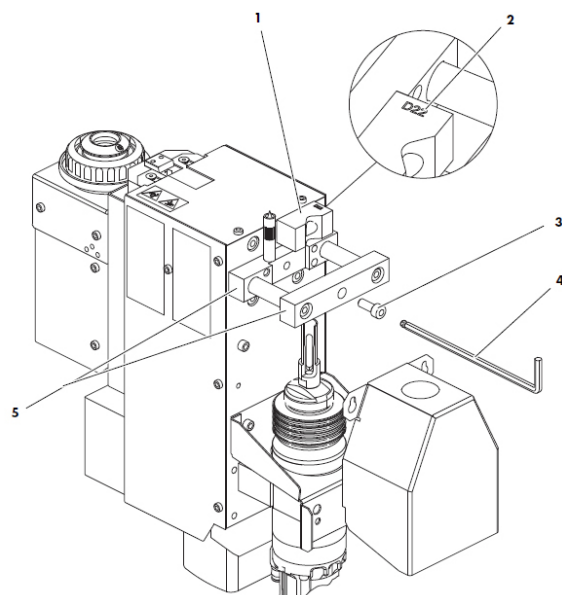

1. Clamping prism
2. Mark for gas nozzle  $\varnothing$
3. Cylinder screw, M8x20
4. Allen key, SW 6
5. Clamping device gas nozzle

### Proceed as follows:

1. Mount the clamping prism (1) in the clamping device (5) from above.

**i** See that a clamping prism (1) that fits the gas nozzle diameter is mounted. You can find the diameter of the prism marked on the prism.

2. Attach the clamping prism with the cylinder screw (3) (tightening torque: 20 Nm).

## 10.6 Mounting the milling cutter

This section describes how to mount the milling cutter.

The parts of the system are depicted in the figure below.

Figure 16: Mounting the milling cutter

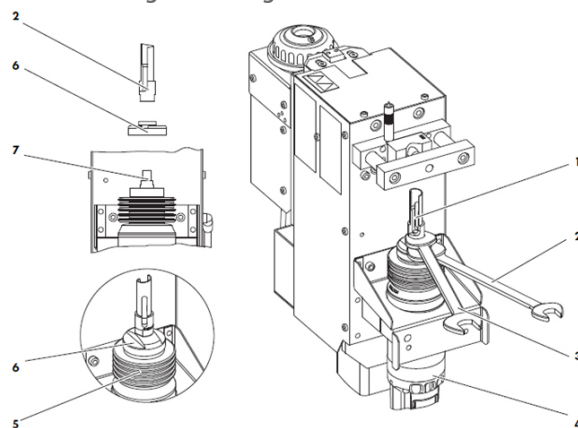

1. Milling cutter
2. Wrench, SW17
3. Wrench, SW21
4. Compressed-air motor
5. Bellows

6. Motor protection cap
7. Motor output shaft

**i** Use only tools with a suitable width across flats when replacing the milling cutter. Motor protection cap (6): SW 21; milling cutter: SW 17.

Ensure that the bellows (5) is in the right position.

### Proceed as follows:

1. Mount the motor protection cap (6).
2. Mount the milling cutter (1) on the compressed-air motor (4).
3. Tighten the milling cutter (1) by means of the wrench, SW17 (2) (minimum tightening torque: 20 Nm), and hold with a wrench, SW21 (3).

For a better mounting, the compressed-air motor should be in the lower clamping and stroke position.

Figure 17: Position of the bellows

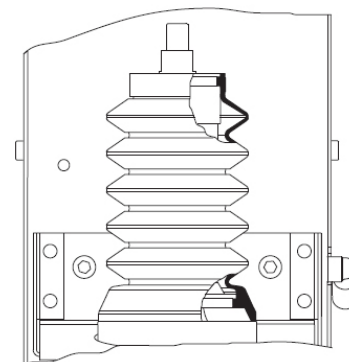

## 10.7 Setting up the clamping position

This section describes how to set up the clamping position.

The parts of the system are depicted in the figure below.

Figure 18: Setting up the clamping position

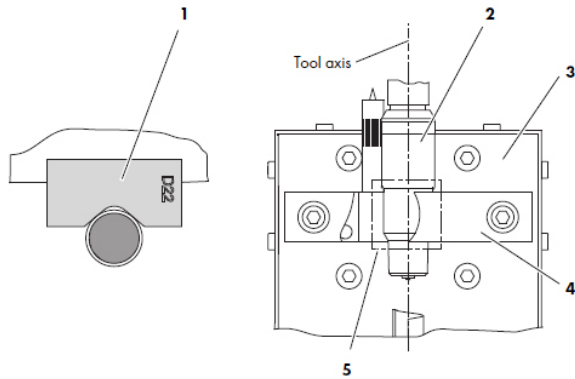

1. Clamping prism
2. Gas nozzle
3. Cleaning station
4. Gas nozzle clamping device
5. Clamping position

**i** Use only clamping prisms and milling cutters that are adjusted to the gas nozzle diameter.

### Proceed as follows:

1. Position the torch with the gas nozzle (2) concentric with the tool axis (milling cutter axis) over the cleaning station (3).
2. Approach the clamping position. Make sure that the cylindrical part of the gas nozzle (2) rests evenly against the clamping prism (1).

**i** The clamping position in the direction of the milling cutter axis should be in the cylindrical part of the gas nozzle. The clamping position (5) can vary, depending on the gas nozzle type.

## 10.8 Setting up the compressed-air motor

Set up the compressed-air motor with the aid of the figure below.

Figure 19: Setting up the compressed-air motor

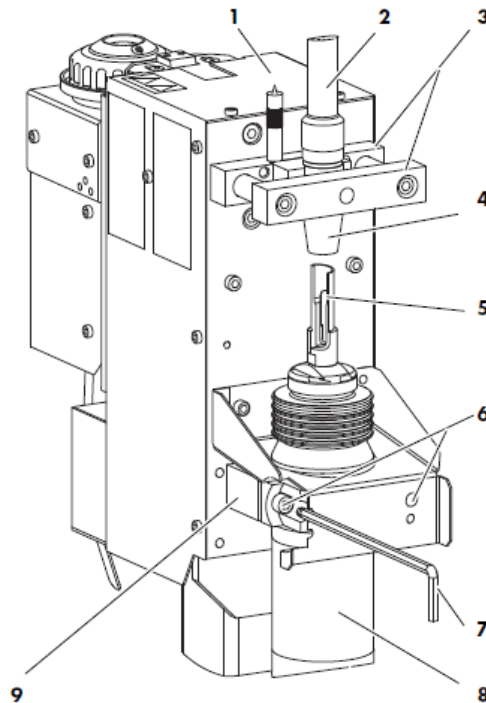

1. Cleaning station
2. Welding torch
3. Gas nozzle clamping device
4. Gas nozzle
5. Milling cutter
6. Clamping screws, M6×45
7. Allen key, SW6
8. Compressed-air motor (stroke down)
9. Motor fastener

**i** Before you can set up the compressed-air motor in its final position, the welding torch has to be positioned in the cleaning station. See Section 9.7.

The motor stroke needs to be in the lower position (8) (stroke down).

## 10.9 Adjusting the height

This section describes how to set up the clamping position.

The parts of the system are depicted in the figure below.

Figure 20: Height adjustment

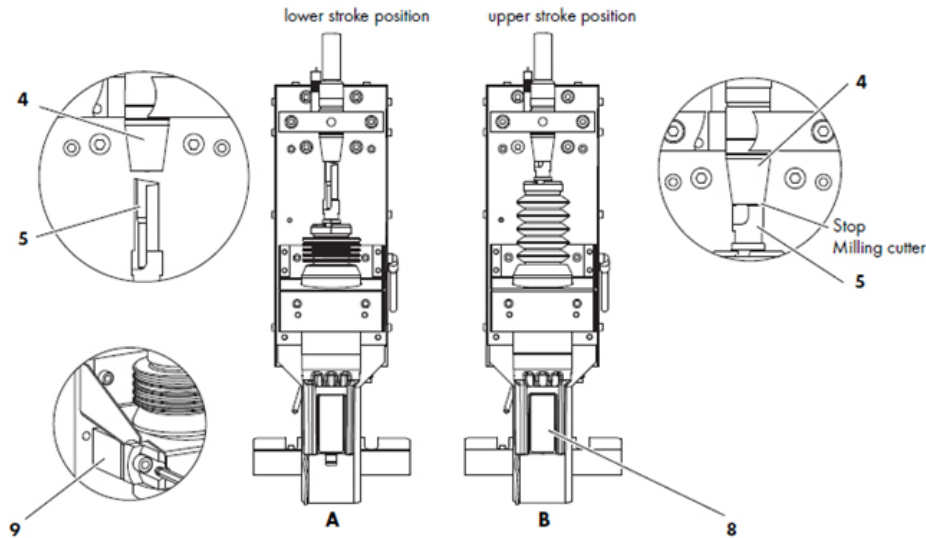

1. Gas nozzle
2. Milling cutter
3. Clamping screws, M8×45
4. Compressed-air motor
5. Motor fastener

See also Section 9.8.

**i** The device has to be depressurized during set-up.

### Proceed as follows:

1. Loosen the clamping screws, M8×45 (6), using an Allen key (8). Meanwhile, hold the compressed-air motor (8).
2. Move the compressed-air motor (8) to the upper stroke position, as shown in Figure 20 (A) (the compressed-air motor can be moved into the upper stroke position manually).
3. Move the compressed-air motor (8) upwards in the fastener (9) until the front side of the milling cutter (5) hits the front side of the gas nozzle (4). See Figure 20 (B).
4. Fasten the clamping screws, M8×45 (6), of the motor fastener (9) (minimum tightening torque: 20 Nm).

## 10.10 Establishing the electrical connection

Figure 21: Circuit diagram

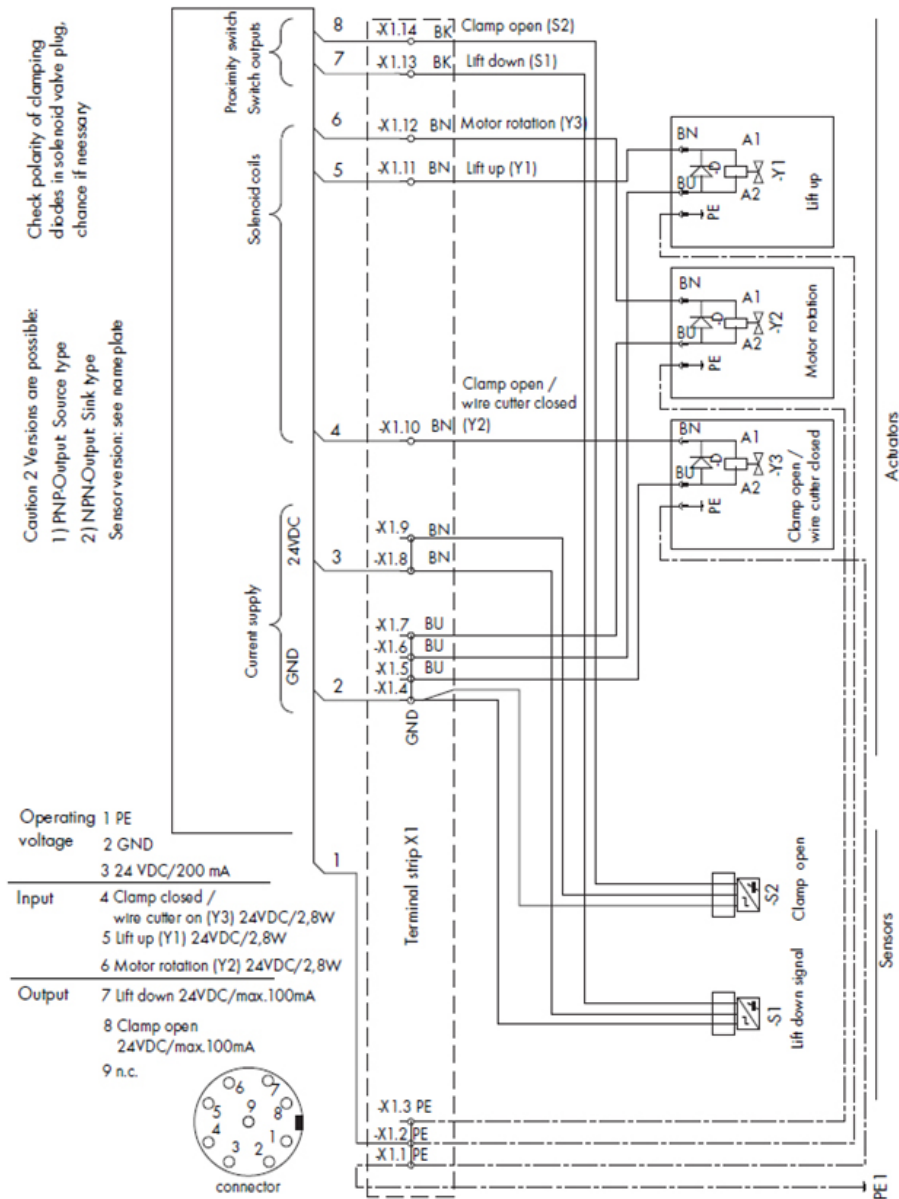

## 10.11 Creating the program for cleaning station operation

This guide presents how to set program flow for the cleaning station operation.

Table 10: Flowchart values

Targets	Description
Home	Initial starting positions
P1	Over cleaning station
P2	Grinding position
P3	Anti-spatter spray injection
P4	Wire cutting position

Digital Outputs	Description
Y1	Clamping cylinder engagement (CLAMP-RELEASE)
Y2	Grinder (UP-DOWN)
Y3	Wire cutter (ON-OFF)
AirBlast	Compressed air blow through cable assembly
WireInch	Wire inching engagement (ON-OFF)

**i** If the operating pressure is too low (<5 bar), adjust the waiting time.

Digital Inputs	Description
DI1	Lift down (Grinder has retracted to safe position when the input is in high state)
DI2	Clamp Open when this input is in high state

### Step-by-step guide

1. Create a new program and name it "Cleaning Station", for example, and save it
2. Start programming by setting the **Home** position anywhere. When assigned, robot can start and end execution of the program it with this position.
3. Set digital outputs (DO) **Y1, Y2, Y3** to **0** (as inactive).

**i** Before calling DO, you need to create DO for each of the parameters. Process of setting the DO is beyond the scope of this guide. Refer to robot manufacturer learning materials for assistance.

4. Set digital inputs (DI), **DI1** and **DI2** to **1** (active).

### Grinding

1. Move gun nozzle to the **P1** position vertically over the cleaning station as shown on the Table 1.
2. By means of a downward linear move, bring the robot to **P2**, the cleaning station position, as shown on the Figure 1.

**i** Refer to the section 10.7 of the Robot Gun Cleaning Station operating manual for assistance with setting up the clamping position and section 10.9 for clamping height adjustment.

3. Set DO **Y1**, clamping cylinder engagement, to **1**
4. Set wait for DI, **DI2 = 0** to finish clamping
5. Set DO **Y2**, grinder (UP-DOWN), as **1**
6. Set also the DO **AirBlast** to **1**
7. Set **Wait** time to = 2-3 sec
8. Set to wait for DO **Y2**, grinder (UP-DOWN), as **0**
9. Set **Wait** for **DI1 = 1**
10. Set also the DO **AirBlast = 0**
11. Set DO **Y1**, clamping cylinder engagement, to **0**
12. Set Wait for **DI2 = 1**

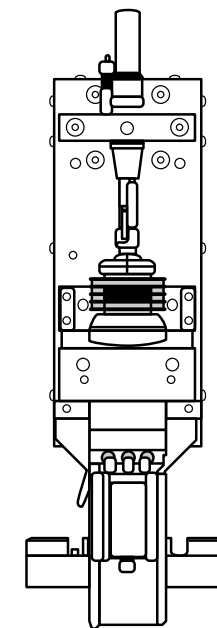

Clamping position  
Figure 1

### Wire trimming

1. Move robot to **P4**.

**i** Keep reasonably small distance (8-10 mm) between the contact tip edge and the wire trimmer edges.

2. Set **WireInch** to **1**
3. Set **Wait** time to = 1-2 sec. to allow enough time for wire inching before cutting
4. Set **WireInch** to **0**
5. Set **Y3** to **1**
6. Set **Wait** time to = 0.5 sec. for cutting action to finish
7. Set **Y3** to **0**

### Anti-spatter spray

1. Move robot to position above the **P3**. Let's call it **Px** position
  2. By means of slow downward linear move, bring the robot to **P3** in order to actuate the anti-spatter spray injector
  3. When gun is in position that actuates the injector, set **Wait** time to = 0.5-1 sec.
  4. Move robot to position above the **Px**
  5. Set also the **Air-blast option** to **1**
  6. Set **Wait** time to = 1 sec.
  7. Set the **Air-blast option** to **0**
- 
8. Move robot to **Home** position

## 10.12 Connecting the pneumatic system

For the supply, a compressed-air hose with a min. internal diameter of 6 mm is required; it is fastened to the housing by means of a screw connection (not included in the delivery). A compressed-air shutoff valve in the supply line is recommended. This allows the Robot Gun Cleaning Station to be depressurized quickly and simply, for carrying out any installation and maintenance work.

Figure 22: Connecting the pneumatic system

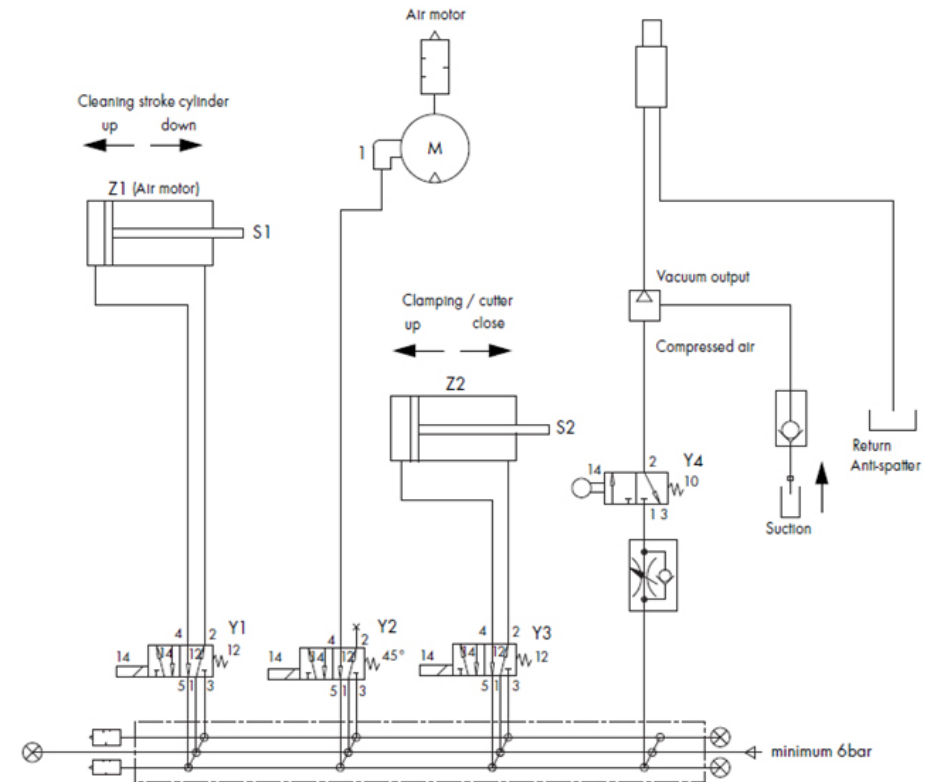

## 11. USING THE ROBOT GUN CLEANING STATION

This section describes how to use the Robot Gun Cleaning Station.

 *As the Robot Gun Cleaning Station is integrated into a welding system, the operating instructions for the welding components, such as the welding torch and robot control, must be observed during operation.*

*Make sure that the Robot Gun Cleaning Station unit is operated with the delivered protective device only.*

### Proceed as follows:

1. Switch on the robot control.
2. Start the welding process.
3. Stop the welding process.

## 12. WITHDRAWING THE ROBOT GUN CLEANING STATION FROM OPERATION

This section describes how to remove the Robot Gun Cleaning Station from service.

 *As the Robot Gun Cleaning Station is integrated into a welding system, the details of its withdrawal from operation depend on the robot control. Please make sure that the shutdown procedures for all components integrated into the welding system are strictly observed.*

1. Proceed as follows: Switch off the robot control.

## 13. MAINTENANCE AND CLEANING

Scheduled maintenance and cleaning are prerequisites for a long service life and trouble-free operation.

Once a month, thoroughly clean the robot mount to remove all dirt and welding spatter.

 **Risk of injury due to unexpected start-up**

For the entire duration of maintenance, servicing, unmounting, and repair work, the following instructions must be adhered to:

- Switch off the power supply.
- Cut off the compressed air supply.
- Pull the power plug.

 **Electric shock**

Dangerous voltage can be produced because of defective cables.

- Check all live cables and connections for proper installation.
- Replace any parts that have suffered damage, deformation, or wear.

 *The maintenance intervals listed are recommended values and assume single-shift operation.*

- Maintenance and cleaning work may only be carried out by qualified and trained specialists.
- Always wear your personal protective clothing when performing maintenance and cleaning work.
- When replacing the liquid-cooled A7 MIG Gun 500-w hose assemblies, make sure that any coolant residues are removed from the robot mount.
- The maintenance intervals listed are recommended values and assume single-shift operation.

The Robot Gun Cleaning Station unit is virtually maintenance-free. However, regularly cleaning and evaluating the mechanical parts that experience stress is necessary in order to maintain its value and to guarantee its full ability to function.

### 13.1 Weekly maintenance

1. Check the condition of the milling cutter.
2. Clean the clamping unit.
3. Cleaning of the injection unit.
4. Unmount the cover of the injection unit (1) and the thrust ring (3), and check the rubber gasket (1). See Section 8.2.
5. Empty the waste container for wire rests.

### 13.2 Monthly cleaning

- Clean the storage tank of the injection unit if it is very dirty.
- We recommend a monthly basic cleaning.



## 14. TROUBLESHOOTING



If the measures described below are not successful, please consult your dealer or the manufacturer.

Also consult the operating instructions for the welding components: the welding power source, welding torch system, re-circulating cooling unit, and so on.

Problem	Cause	Solution
Compressed-air motor does not run	<ul style="list-style-type: none"> <li>Compressed-air supply or hose connection interrupted</li> <li>Compressed-air supply or hose connection interrupted</li> </ul>	<ul style="list-style-type: none"> <li>Check all supply lines leading to the cylinder and the fittings</li> <li>Motor defective; replace</li> <li>Replace directional valve Y2</li> </ul>
Insufficient cleaning	<ul style="list-style-type: none"> <li>Milling cutter defective or worn out</li> </ul>	<ul style="list-style-type: none"> <li>Replace milling cutter</li> </ul>
Welding torch parts damaged	<ul style="list-style-type: none"> <li>Wrong equipment parts</li> </ul>	<ul style="list-style-type: none"> <li>Check torch-dependent parts (milling cutter and clamping prism)</li> <li>Check immersion depth of torch</li> </ul>

Table 12: Troubleshooting the injection unit

Problem	Cause	Solution
No injection	<ul style="list-style-type: none"> <li>Insufficient fluid level</li> <li>Compressed-air supply or hose connections interrupted</li> <li>Directional valve Y4 does not switch</li> </ul>	<ul style="list-style-type: none"> <li>Add more anti-spatter fluid</li> <li>Check all supply lines leading to the cylinder and the fittings</li> <li>Replace directional valve Y4</li> </ul>
Too much or too little spray mist	<ul style="list-style-type: none"> <li>Metering quantity incorrectly adjusted</li> </ul>	<ul style="list-style-type: none"> <li>Change setting of throttle screw</li> </ul>
Too little spray mist	<ul style="list-style-type: none"> <li>Injection time too short</li> <li>Operating pressure too low</li> </ul>	<ul style="list-style-type: none"> <li>Injection time greater than waiting time</li> <li>Check operating pressure</li> </ul>
No spray mist	<ul style="list-style-type: none"> <li>Operating pressure too low</li> </ul>	<ul style="list-style-type: none"> <li>Check operating pressure</li> </ul>

Table 13: Troubleshooting the wire-cutting device

Problem	Cause	Solution
No cutting function	<ul style="list-style-type: none"> <li>Compressed-air supply or hose connection interrupted</li> <li>Directional valve Y3 does not switch</li> </ul>	<ul style="list-style-type: none"> <li>Check all supply lines leading to the cylinder and the fittings</li> <li>Check signal output of robot control</li> <li>Replace directional valve Y3</li> </ul>
Insufficient cutting capacity	<ul style="list-style-type: none"> <li>Too low working pressure</li> <li>Roughly running slide</li> <li>Worn cutting edge</li> </ul>	<ul style="list-style-type: none"> <li>Check the adjustment of the pressure regulator: min. 5 bar, max. 8 bar</li> <li>Unmount movable parts; clean and lubricate them</li> <li>Clean more often</li> <li>Change approach position P4</li> <li>Change the cutter</li> </ul>
Free wire end is bent	<ul style="list-style-type: none"> <li>The wire has no contact with the fixed jaws</li> <li>Counter-support jammed</li> </ul>	<ul style="list-style-type: none"> <li>Correct the approach position of the welding torch</li> <li>Unmount movable parts; clean and oil them</li> <li>Tighten the mounting screws</li> </ul>

## 15. UNMOUNTING

Unmounting may only be carried out by specialist personnel. Please make sure that the shutdown procedures are strictly observed before the unmounting is started. Make sure to include also the components integrated into the welding system.

 *Risk of injury due to unexpected start-up*

For the entire duration of maintenance, servicing, unmounting, and repair work, the following instructions must be adhered to:

- Switch off the power supply.
- Cut off the compressed air supply.
- Pull the power plug.

 *Observe the information given in Chapter 11.*

## 16. DISPOSAL

For disposal, the locally applicable regulations, laws, provisions, standards, and guidelines must be observed. For the welding torch system to be properly disposed of, it must be unmounted first.

## 17. MATERIALS

This product consists for the most part of plastics, steel, and non-ferrous metals. Steel and non-ferrous metals can be melted down, so iron materials are almost infinitely recyclable. The plastic materials used are marked in preparation for appropriate sorting of the materials for later recycling.

